

# **NISSAN OUTBOARD MOTORS**

**NS 25**

**NS 30**

**NS 40**



**OWNER'S OPERATING MANUAL**

**Copyright © 2007 Nissan Marine Co. Ltd. All rights reserved. No part of this manual may be reproduced or transmitted in any form or by any means without the express written permission of Nissan Marine Co., Ltd.**

The warranty will cover only your NISSAN product and will not cover the boat the product is mounted on, the trailer, equipment, or accessories associated with the product.

### **Serial Number**

In the space below, please record the engine's serial number (indicated both on the lower motor cover and on the cylinder block). This number will come in handy in the event of theft or to help in quickly identifying the product type.

Serial Number: \_\_\_\_\_

### **To You, Our Customer:**

Thank you for selecting a NISSAN product. You are now the proud owner of an excellent outboard engine that will serve you for many years to come.

We would like to point out that carefree usage can only be assured on condition that this manual is read through in its entirety and the maintenance routines described later in this manual are followed carefully. Should difficulty arise with the engine, please follow the troubleshooting procedures listed at the end of this manual. If the problem persists, contact an authorized NISSAN service shop or your dealer.

We hope you will get much enjoyment from this product and wish you good luck in your boating adventures.

NISSAN MOTOR CO., LTD.

### **NOTICE: DANGER/WARNING/CAUTION/Note**

Before operating your outboard motor, be sure to thoroughly read and understand this Owner's Manual and follow all of the instructions shown. Of particular importance is information preceded by the words "DANGER," "WARNING," "CAUTION," and "Note." *Always pay special attention to such information to ensure safer and trouble-free operation at all times.*

## **▲ DANGER**

Failure to observe will result in severe personal injury or death.

## **▲ WARNING**

Failure to observe could result in severe personal injury or death.

## **▲ CAUTION**

Failure to observe could result in minor personal injury or product or property damage.

### **Note:**

This instruction provides special information to facilitate the use or maintenance of the outboard or to clarify important points.

## **EMERGENCY STOP SWITCH**

The stop switch will cut off the engine when the stop switch line is pulled out. This line can be attached to the body of the operator, effectively preventing injuries from the propeller in case he/she falls overboard.

We highly recommend use of the stop switch line because it can save the life of the operator if something bad happens. However, we would also like to point out the drawbacks of the switch. Accidental activation of the switch (such as the line being pulled out in heavy seas) could cause passengers to lose their balance and even fall overboard, or it could result in loss of power in heavy seas, strong currents, or high winds. Loss of control while mooring is another potential hazard.

To prevent such hazardous situations, the 500 mm line is coiled and can extend to a full 1,300 mm.

## **WARNINGS**

As the operator/driver of the boat, you are responsible for the safety of those aboard and those in other crafts around yours, and for following local boating regulations. Therefore you should possess thorough knowledge of correct operation of the boat, its accessories, and the engine. To learn about the correct operation and maintenance of the engine, please read through this manual carefully.

It is very difficult for a person standing or floating in the water to take evasive action should he or she see a power boat heading in his/her direction, even at a slow speed. Therefore, when your boat is in the immediate vicinity of people in the water, the engine should be shifted to neutral and shut off.

SERIOUS INJURY IS LIKELY IF A PERSON IN THE WATER MAKES CONTACT WITH A MOVING BOAT, GEAR HOUSING, PROPELLER, OR ANY SOLID DEVICE RIGIDLY ATTACHED TO A BOAT OR GEAR HOUSING.

It is the operator's responsibility to perform all safety checks and to ensure that all lubrication and maintenance instructions are complied with for safe operation. It is also the operator's responsibility to return the unit to the local dealer for periodic inspection.

Correct periodic maintenance and good care of this outboard engine will lessen the chance of problems and keep overall operating expenses at a minimum.

### **SERVICING, REPLACEMENT PARTS, & LUBRICANTS**

Only let an authorized NISSAN service shop perform servicing or maintenance on this product. Be sure to use genuine parts and genuine lubricants or recommended lubricants.

### **MAINTENANCE**

As the owner of this outboard engine, you should be acquainted with its correct maintenance. Please comply with all instructions on lubrication and maintenance, and return the engine to the dealer or service shop for periodic inspection at the prescribed intervals.

Troublefree operation cannot be expected unless the engine receives adequate periodic maintenance. If maintenance is performed periodically, it is not likely that a costly overhaul will ever be required.

### **USE OF SERVICE SHOP**

When subjecting your NISSAN product to a check or repair, please be sure to use a NISSAN dealer authorized by NISSAN or a NISSAN agent.

# CONTENTS

	Page
<b>1. SPECIFICATIONS</b> .....	1
<b>2. NAME OF PARTS</b> .....	2
<b>3. INSTALLATION</b> .....	8
1. MOUNTING THE ENGINE(S) ON BOAT .....	8
2. INSTALLING THE REMOTE CONTROL DEVICE .....	9
3. INSTALLING THE BATTERY .....	15
<b>4. PRE-OPERATING PREPARATIONS</b> .....	16
1. FUEL AND OIL .....	16
2. BREAKING IN THE ENGINE .....	17
<b>5. ENGINE OPERATION</b> .....	18
1. STARTING .....	18
2. WARMING UP THE ENGINE .....	23
3. FORWARD AND REVERSE .....	24
4. STOPPING .....	26
5. TRIM ANGLE .....	27
6. TILT UP, TILT DOWN .....	28
7. SHALLOW WATER OPERATION .....	29
<b>6. REMOVING AND CARRYING THE MOTOR</b> .....	31
1. REMOVING THE MOTOR .....	31
2. CARRYING THE MOTOR .....	31
3. STORING THE MOTOR .....	31
<b>7. TRAILERING</b> .....	32
<b>8. ADJUSTMENT</b> .....	33
<b>9. INSPECTION AND MAINTENANCE</b> .....	34
1. DAILY INSPECTION .....	35
2. PERIODIC INSPECTION .....	39
3. OFF-SEASON STORAGE .....	42
4. PRE-SEASON CHECK .....	43
5. MOTOR SUBMERGED IN WATER .....	44
6. COLD WEATHER PRECAUTIONS .....	44
7. CHECKING AFTER STRIKING UNDERWATER OBJECT .....	44
<b>10. TROUBLESHOOTING</b> .....	45
<b>11. TOOL KIT AND SPARE PARTS</b> .....	47
<b>12. OPTIONAL ACCESSORIES</b> .....	48
<b>13. PROPELLER TABLE</b> .....	50
<b>14. WIRING DIAGRAM</b> .....	51

# 1. SPECIFICATIONS

MODEL	25C <sub>3</sub>	25C <sub>3</sub> EF	25C <sub>3</sub> EP	30A <sub>4</sub>	30A <sub>4</sub> EF	30A <sub>4</sub> EP	40C	40C EF	40C EP		
Overall Length, mm	884		600	884		600	919		600		
Overall Width, mm	412		355	412		355	415		355		
Overall Height, mm	S L UL		1116	1243	1370		1116	1245	1372		
Transom Height, mm	S L UL		435 562 689								
Weight, kg	S L UL	Approx.	51 52.5 54	55 56.5 58	54 55.5 57	51 52.5 54	55 56.5 58	54 55.5 57	59 60.5 62	62 63.5 65	60.5 62 63.5
Output, kW		18.6				22.4			29.6		
Max. Operating Range		5,000-6,000				5,150-5,850			5,200-5,800		
Number of Cylinders						2					
Piston Displacement, mL			428.5						493		
Bore x Stroke, mm			68 x 59						70 x 64		
Exhaust System						through hub exhaust					
Lubrication System						engine oil mixed gasoline					
Cooling System						forced water cooling					
Starting System			manual	electric starter motor*	manual	electric starter motor*	manual	electric starter motor*	electric starter motor*		
Ignition						Flywheel Magneto C.D. Ignition					
Spark Plugs						NGK B7HS-10/BR7HS-10 or CHAMPION LB2C/RLB2C (gap 1.0 mm)					
Alternator	V W					12 80					
Trim Stages						6					
Engine Oil Mixing Ratio						unleaded gasoline 50: Genuine 2-stroke Engine Oil 1					
Gear Oil						Genuine Gear Oil API GL5, SAE #80-90, Approx. 280 mL/25 & 30, 420 mL/40					
Fuel Tank Capacity, L						25					
Gear Reduction Ratio				12 : 23					13 : 25		

\*: with manual

## 2. NAME OF PARTS

25C<sub>3</sub> / 30A<sub>4</sub>

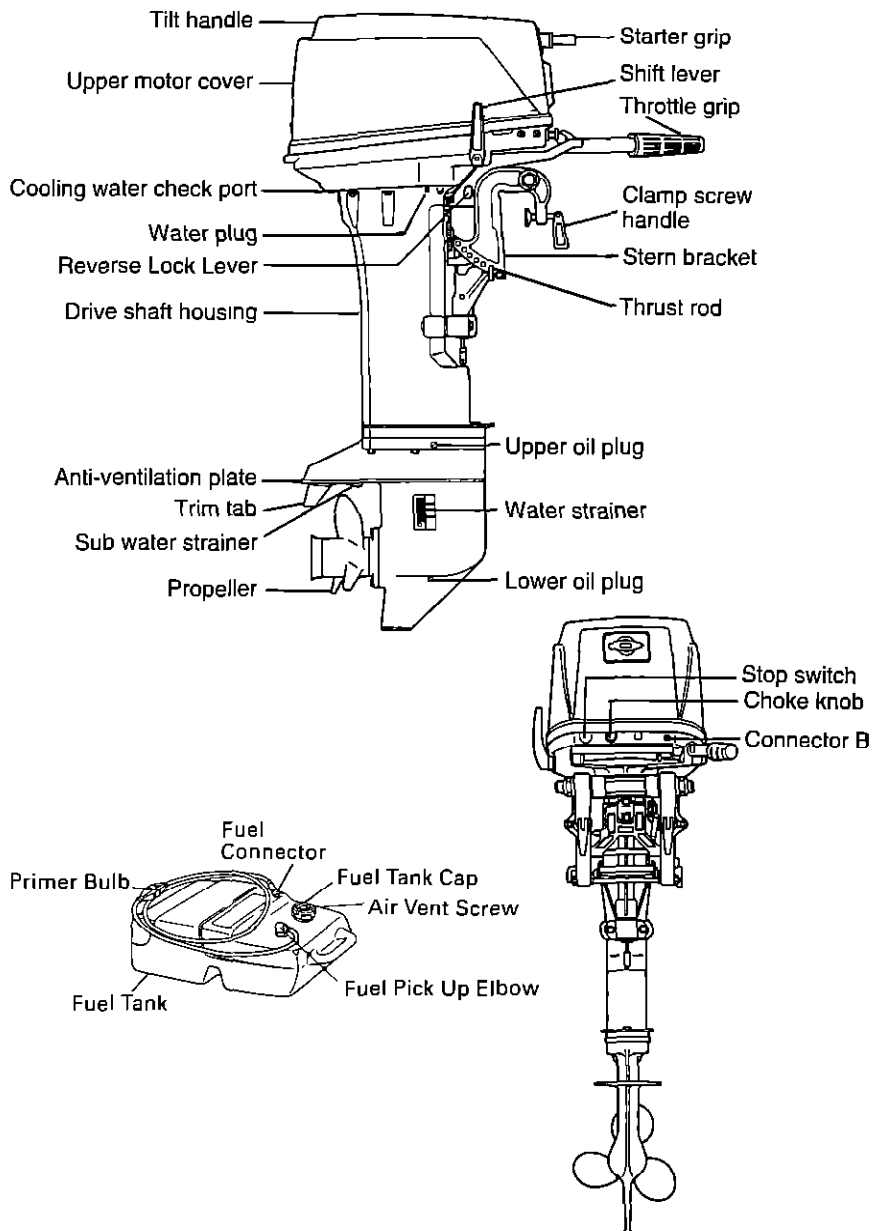



# 25C<sub>3</sub>EF / 30A<sub>4</sub>EF

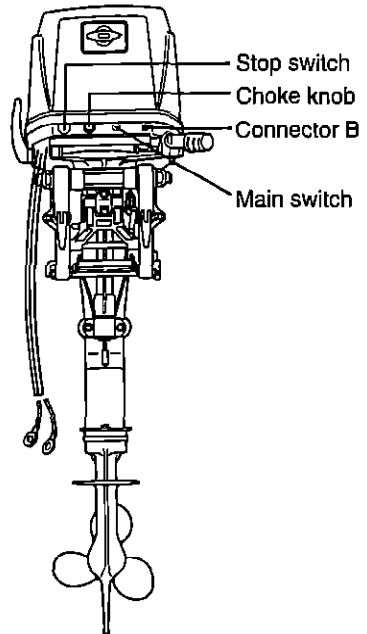
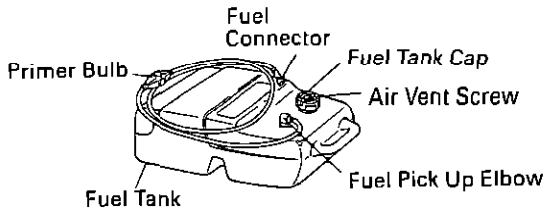
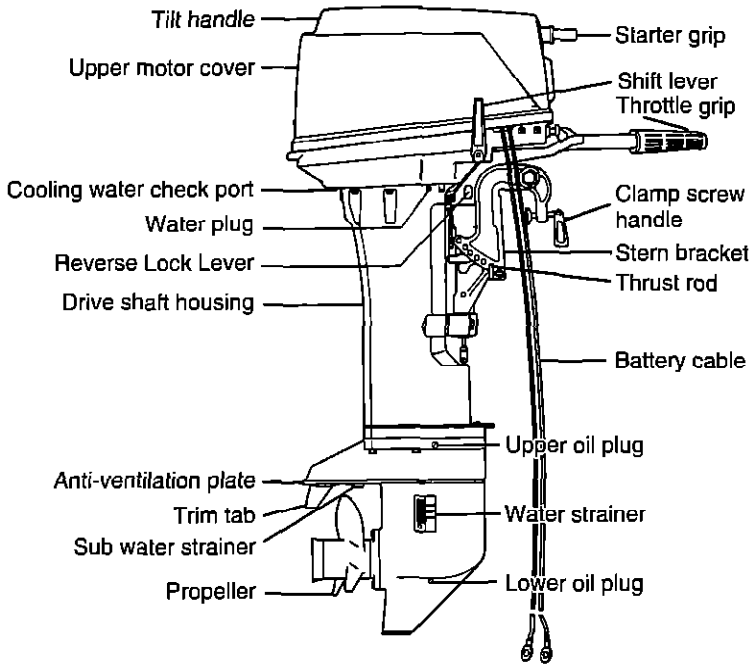

# 25C<sub>3</sub>EP / 30A<sub>4</sub>EP

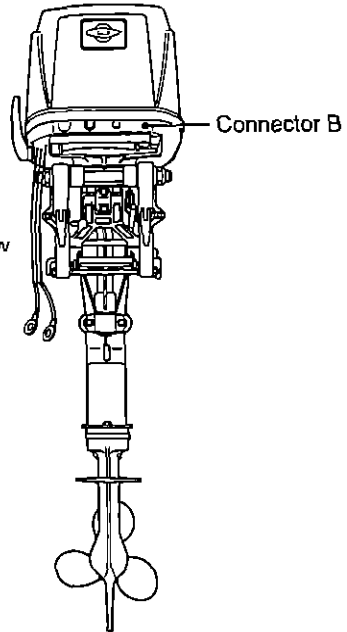
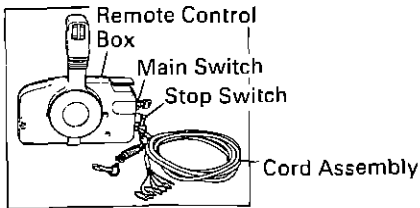
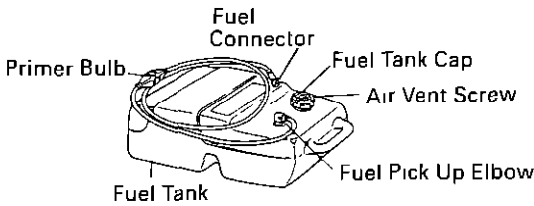
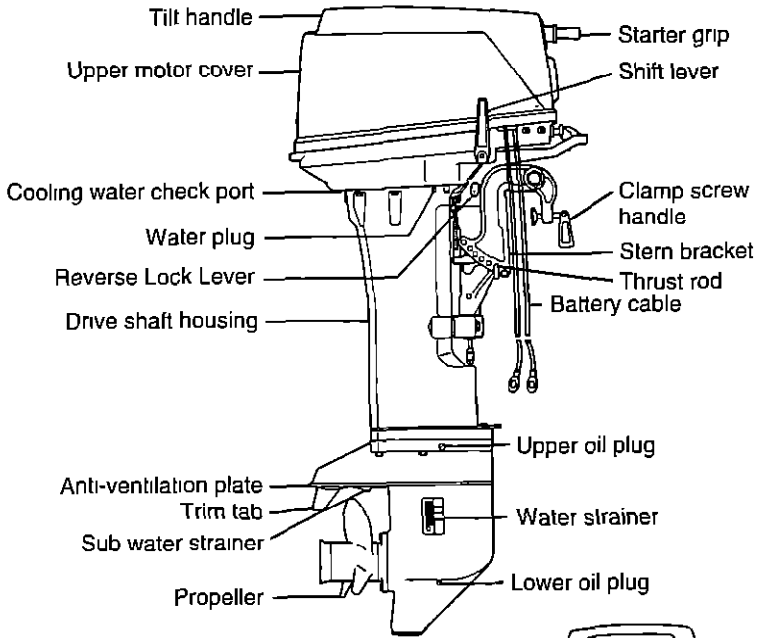

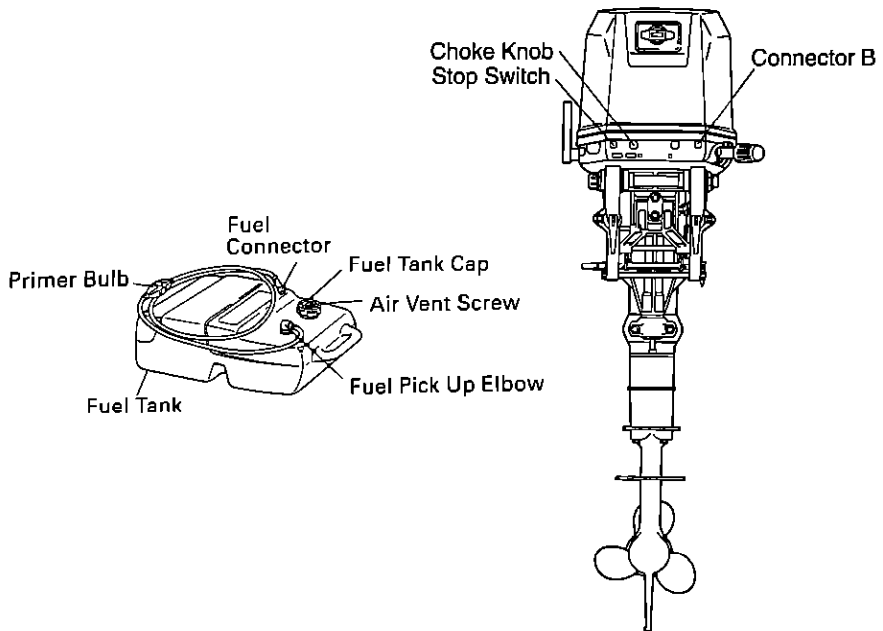
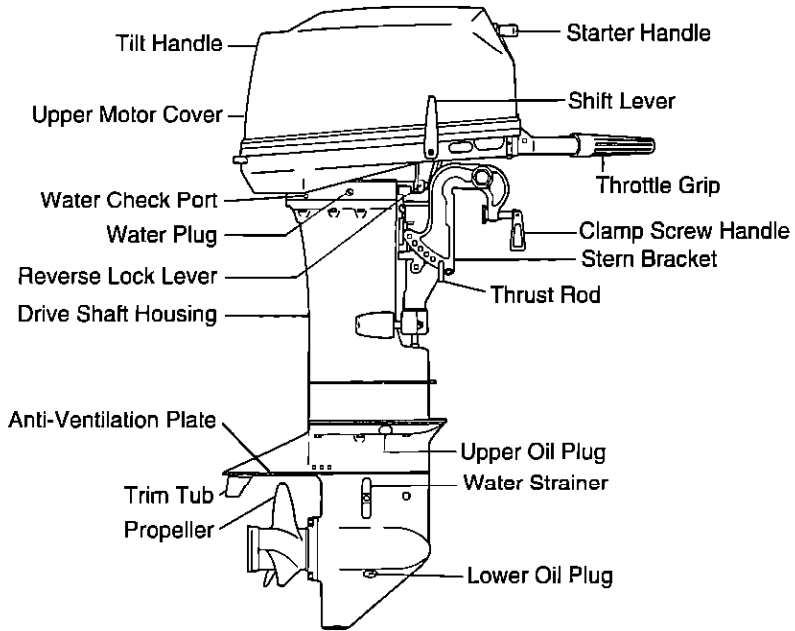

# 40CEF

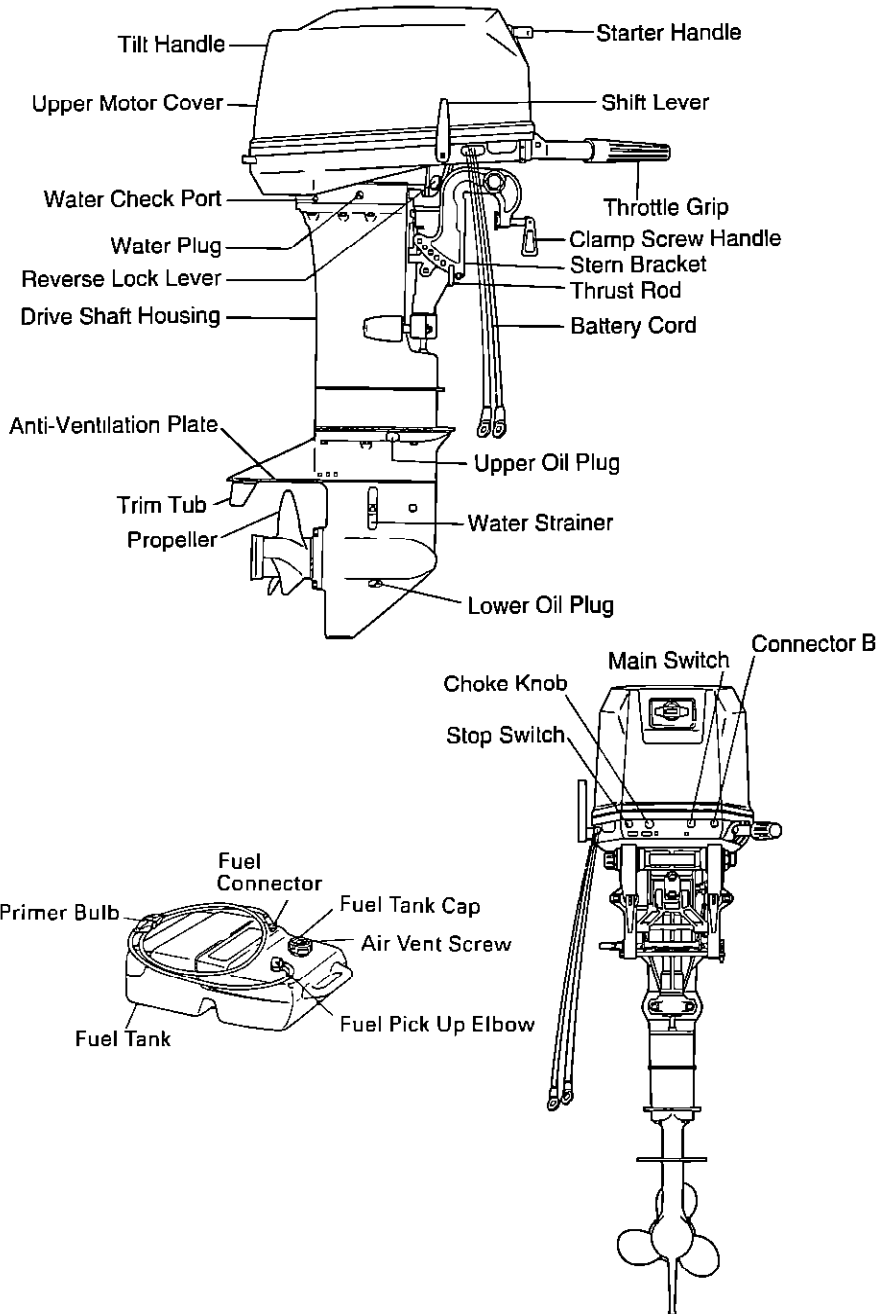

# 40CEP

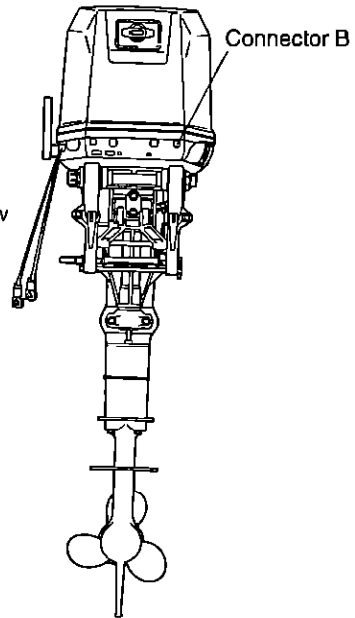
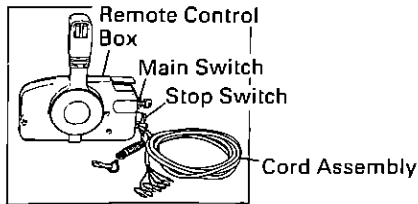
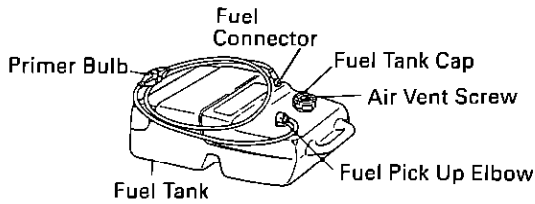
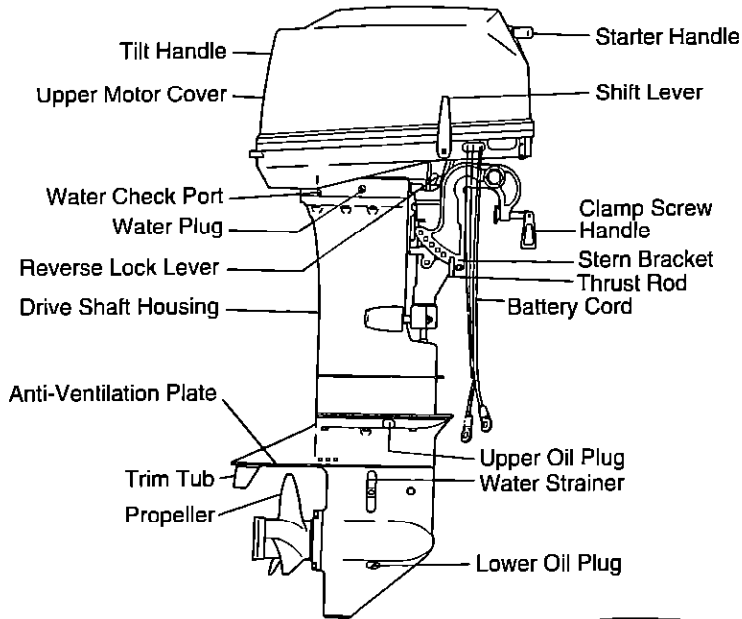

### 3. INSTALLATION

#### ▲ WARNING

Most boats are rated and certified in terms of their maximum horsepower, and this is shown on the boat's certification plate. Do not equip your boat with an outboard that exceeds this limit. If in doubt, contact your dealer.

Do not operate the engine unit until it has been securely mounted on the boat in accordance with the instructions below.

#### 3-1. Mounting the engine(s) on boat

(1) Position . . . . above keel line

- Set engine center of boat (Fig. 1)
- Distance between engines if two are mounted approximately 580 mm (22.8")

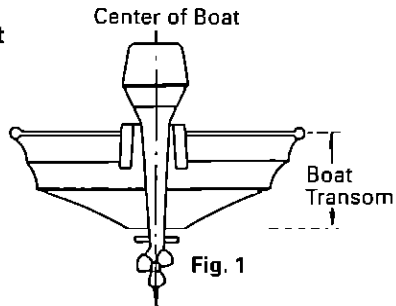

(2) Transom matching

Be sure that the anti-ventilation plate of the outboard is below the water surface when running with the throttle wide open. (Fig. 2)

If the above condition cannot be met due to the shape of the bottom of your boat, please consult the dealer.

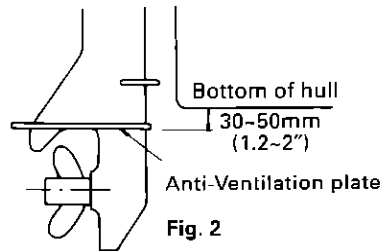

(3) To attach the engine to the boat, tighten the clamp screws by turning their handles. Also, tighten the bolts. (Fig. 3a)

Make sure the engine is secure (Fig. 3b) to prevent loss or damage.

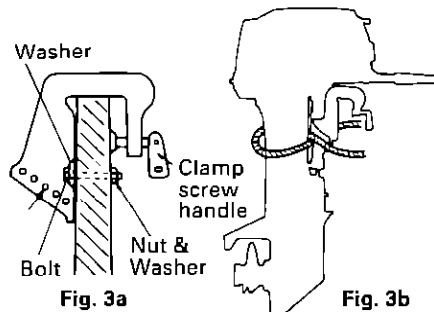

### 3-2. Installing the remote control device

It is recommendable to consult with your dealer for installation and adjustment of the remote control device.

- (1) Installation of the Remote Control Cables (Box side)  
Follow the instruction manual provided with the remote control box.
- (2) Installation of the Remote Control Box on your boat  
Follow the instruction manual provided with the remote control box.
- (3) Installing the Remote Control Cable (engine side) and the Cord Assembly (Wiring Harness)

#### 25C<sub>3</sub> EP / 30A<sub>4</sub> EP

##### ① Fitting of Holder Cap and Sleeve B Guide

- Throttle side . . . . Fit the Holder Cap to the end of the Cable and fix it by the Nut.

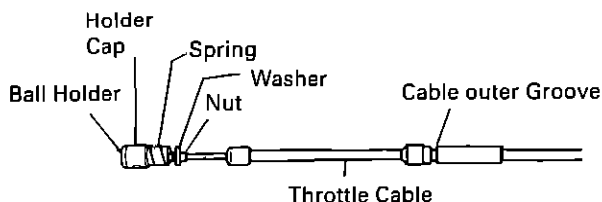

- Shift side . . . . . Fit the Sleeve B Guide to the end of the Cable and fix it by the Nut.

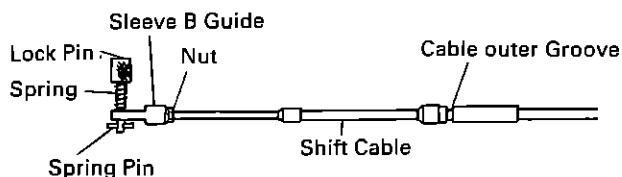

② Fitting of Remote Control Cable to Engine

- Throttle side

Set the Throttle cable to the Cable clip and then connect the Holder cap to the Ball joint of Advancer arm.

- Shift side

Set the Shift cable to the Cable clip and then insert the Lock pin at the Shift lever fitting hole and turn it 90° to lock it.

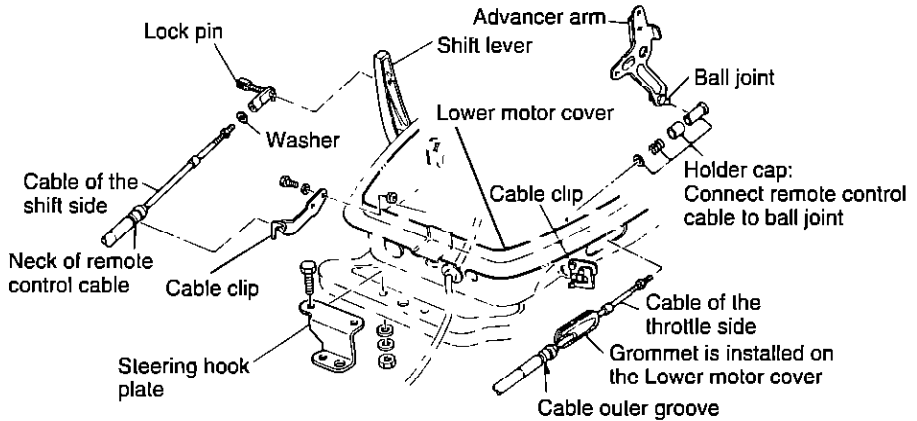

**Note:**

Put the control lever on the Neutral position and the Neutral warm-up lever in the fully closed position.



**Note:**

Confirm whether the engine side shift is in gear when shifting the control lever of the Remote Control Box to its first position in Forward or Reverse (about 32°) and whether the throttle of the carburetor is fully open when shifting the lever further.

Confirm whether the carburetor's throttle is fully closed when the control lever is shifted to the Neutral position. If it is not, adjust the position of the ball holder.

③ Connecting the Cord assembly (Wiring Harness)

- Pass the Cord assembly from the Remote control box through the hole in the Lower motor cover and connect the electric terminals and then clamp the Cord assembly according to the drawing below.

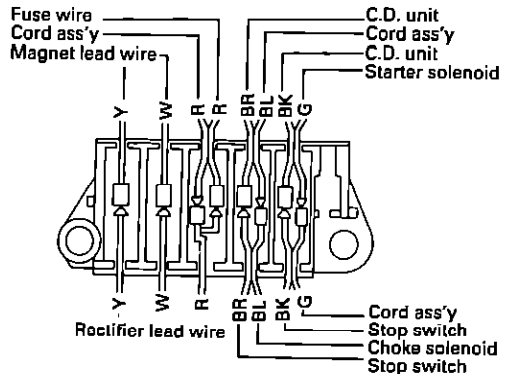
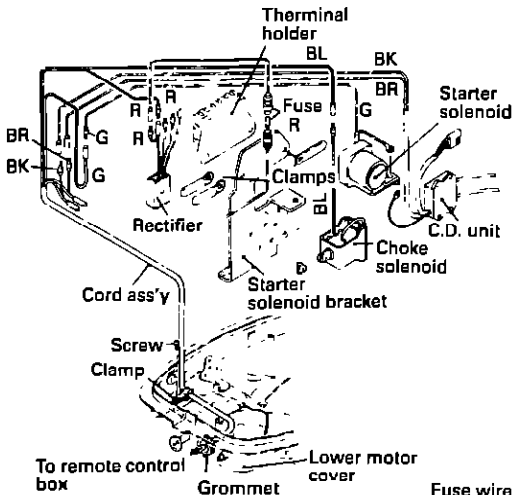

## M40C EP

### ① Fitting of Holder Cap and Grommet.

- Throttle side
  - Take out the grommet from the advancer arm side of the lower motor cover.
  - Set the grommet on the cable after making a hole in grommet.
  - Attach holder cap to cable and lock in position by nut.

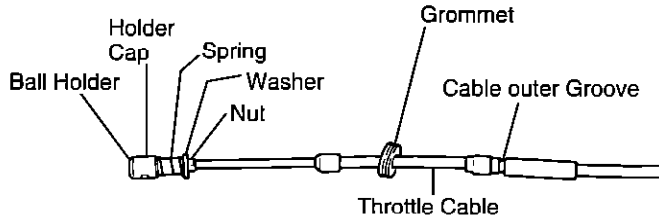

- Shift side
  - Take out the grommet from the shift lever side of the lower motor cover.
  - Set grommet in position.
  - Attach holder cap to cable and lock in position by nut.

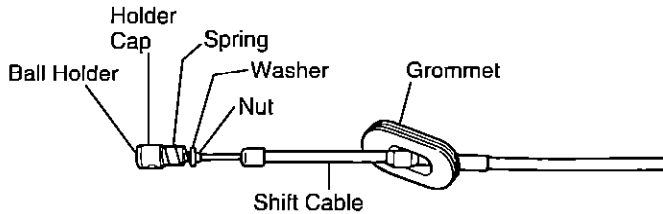

② Fitting of Remote Control Cable to Engine

● Throttle side

Set the Throttle cable to the Cable clip and then connect the Holder cap to the Ball joint of Advancer arm.

● Shift side

Set the Shift cable to the Cable holder and then connect the Holder cap to the Ball joint of the Starter lock arm.

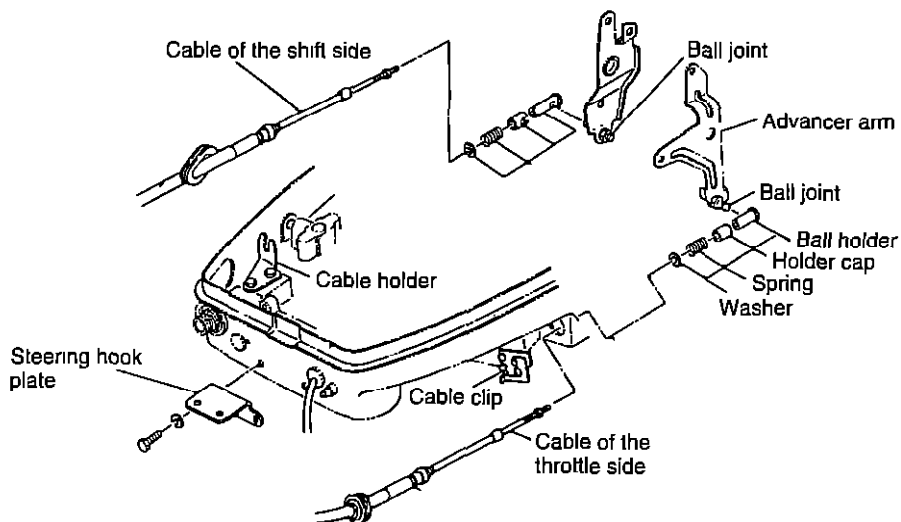

**Note:**

Put the control lever on the Neutral position and the Neutral warm-up lever in the fully closed position.

**Note:**

Confirm whether the engine side shift is in gear when shifting the control lever of the Remote Control Box to its first position in Forward or Reverse (about 32°) and whether the throttle of the carburetor is fully open when shifting the lever further.

Confirm whether the carburetor's throttle is fully closed when the control lever is shifted to the Neutral position. If it is not, adjust the position of the ball holder.

③ Connecting the Cord assembly (Wiring Harness)

- Pass the Cord assembly from the Remote control box through the hole in the Lower motor cover and connect the electric terminals and then clamp the Cord assembly according to the drawing below.

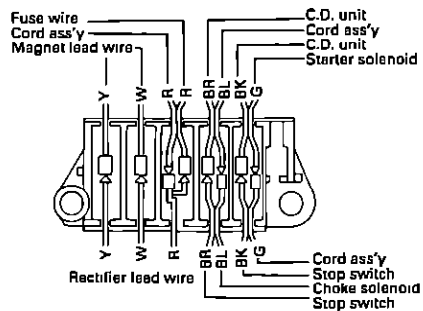
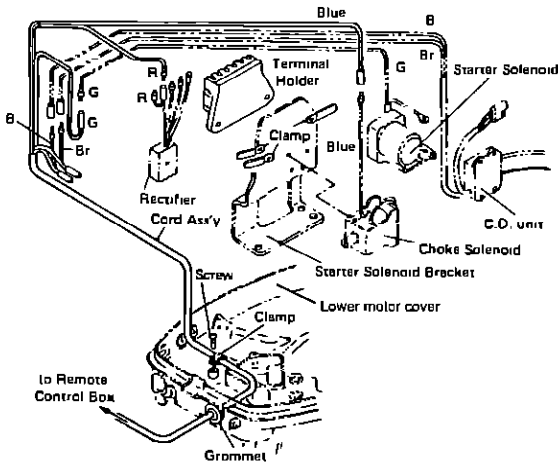

### 3-3. Installing the battery

- (1) Place the battery box in a convenient position away from possible spray damage. Securely fasten both the box and battery so they do not shake loose.

A 12 V battery with a recommended capacity of 70 AH is recommended.

## ▲ WARNING

Hydrogen gas is generated when a battery is charged. Therefore, keep the battery well ventilated during charging.

Electric sparks, cigarette smoking and other sources of fire must be avoided in the charging area to prevent explosion of the battery.

\*The battery fluid (electrolyte) contains sulfuric acid.

If any electrolyte is spilled on the skin, clothes, etc., wash with copious amounts of water and consult a doctor. Always use safety glasses and rubber gloves when handling the battery.

Remark: Further to notice on the label of your battery.

#### Note:

- (1) Make sure that the battery leads do not get stuck between the motor and boat when turning, etc.
- (2) The starter motor may fail to operate if the leads are incorrectly connected.
- (3) Be sure to correctly connect the (+) and (-) leads. If not, the charging system will be damaged.
- (4) Do not disconnect the battery leads from battery while the engine operation, the electrical parts could be damaged.
- (5) Always use a fully charged battery.

- (2) Connect the positive lead (+) to the positive terminal (+) of the battery, and then connect the negative lead (-). When disconnecting the battery always remove the negative lead (-) first. After connecting the positive terminal (+), securely place a cap on it to prevent short circuits.

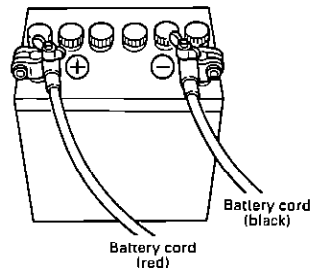

## 4. PRE-OPERATING PREPARATIONS

### 4-1 Fuel and oil

#### DANGER

Gasoline vapors are present, an errant spark could cause an explosion or fire.

- Do not smoke near gasoline.
- Do not overfill gasoline.  
If any gasoline is spilt, wipe it up immediately.
- Stop the engine before fill gasoline into the fuel tank.

- **Required types**

#### **Gasoline**

Unleaded gasoline is recommended for outboard motors.

The minimum octane rating should be 87 based on the pump-posted octane rating method (91 based on the research octane rating method).

#### Note:

Gasoline containing alcohol, methanol (methyl), or ethanol (ethyl), may cause:

- Wear and damage to bearings, pistons, piston rings, and cylinder liners.
- Corrosion of metal parts.
- Deterioration of rubber parts and plastic parts.

#### **Engine Oil**

Use genuine engine oil or the other recommended one, that is, TCW3. We can not recommend any other two-stroke engine oil.

#### **Caution**

Do not mix different brands of oil. The mixing of different brands, or different kinds even if the same brand, may cause gelling, resulting in blockage of filter screens. This may lead to serious engine damage due to the lack of lubrication.

- Mixing ratio (50:1)  
unleaded gasoline 50: GENUINE ENGINE OIL  
or  
recommended engine oil (TCW3) 1

Note:  
You must break in the engine by operating it for 10 hours with mixing ratio of 25:1.

- Use of low-quality gasoline results in a short engine life as well as starting difficulties and other engine trouble.

#### 4-2 Breaking In the Engine

##### 1) Running time ..... 10 hours

Time	0 min.-	10 min.-	1 hr.-	2 hrs.-	10 hrs.-
<b>Method of operation</b>	Idling or trolling	Throttle open less than 1/2 way (about 3,000 rpm)	Throttle open less than 3/4 of the way (about 4,000 rpm)	Throttle open 3/4 of the way (about 4,000 rpm)	Normal operating
<b>Conditions</b>	Cruising at no more than minimum speed		A full-throttle run is allowed for 1 min. every 10 min.	A full-throttle run is allowed for 2 min. every 10 min.	

##### 2) Fuel mix ratio for break-in running

Gasoline 25: Genuine Engine Oil 1

- 25:1 when using genuine engine oil or the recommended one (TCW3)

## 5. ENGINE OPERATION

### 5-1. Starting

#### ⚠ WARNING

Be sure to connect the emergency stop hook to your waist clothing. The engine will shut down if the hook's line becomes disconnected from the engine.

**Note:**

The engine will not start unless this switch has been properly connected and locked beforehand.

**Note:**

Do not operate the engine without cooling water.

- ① Loosen the air vent screw on the tank cap.

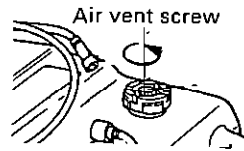

- ② Attach the fuel connector to the engine connector. The arrow mark on the primer valve should be facing the engine.

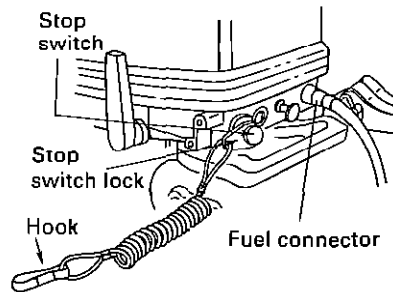

- ③ Feed fuel to the carburetor by squeezing the primer valve until it is firm.

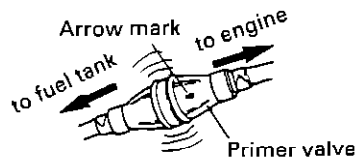



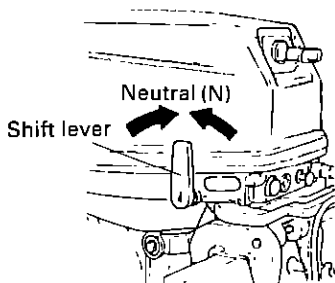

- ④ Place the shift lever in the Neutral position.

Be sure that the shift is in neutral when starting the engine.

This model is provided with a function that prevents starting in gear protection.

### ▲CAUTION

If the motor somehow does start in gear, do not use it. Contact your authorized dealer.

- ⑤ Turn the throttle grip until the mark on the grip faces the triangular mark on the steering handle.

- ⑥ Pull out the choke knob all the way.  
(No choke operation is necessary when the engine is warm.)

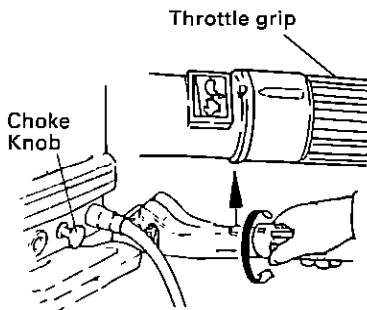

## 25C<sub>3</sub> / 30A<sub>4</sub> / 40C type

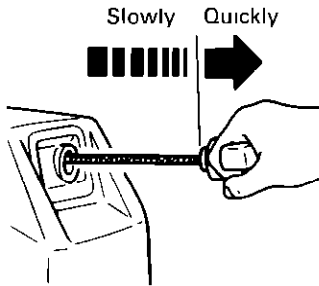

### Note: Starting Guideline for 25C<sub>3</sub> / 30A<sub>4</sub>

Temperature	Starting procedure
Over 25°C (77 F)	Turn the throttle grip to original position, pull the choke knob and recoil starter once. Turn the throttle grip to "START" position, push the choke knob back, then pull the recoil starter until the engine starts
15°C to 25°C (59° to 77°F)	Turn the throttle grip to "START" position, and pull the choke knob and recoil starter once. Push the choke knob back, and pull the recoil starter until the engine starts
Below 15°C (59 F)	Turn the throttle grip to "START" position, pull the choke knob and the recoil starter until combustion occurs. Then push the choke knob back, and pull the recoil starter until the engine starts.

- ⑦ Pull the starter handle slowly until you feel resistance. Then pull it quickly.

## EF type

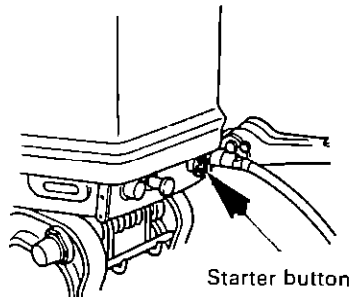

- ⑦ Push the starter button.
- ⑧ Release pushing the button when the engine has started.

### Note:

If use the choke knob for the engine start, push back it when the engine has started.

## EP type

- ④ Insert the main switch key.
- ⑤ Set the control lever in the Neutral position.  
Raise the Neutral warm-up lever.

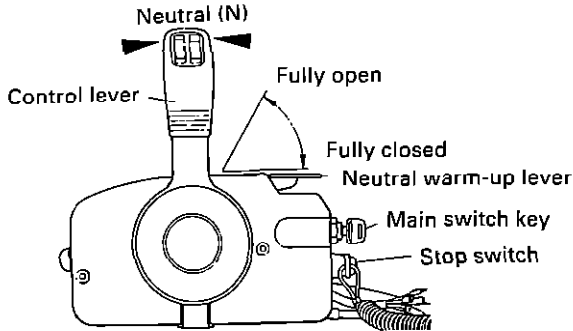

- ⑥ Turn the main switch key to START position. Then, continuously push the key to operate the choke.  
Note: Choke operation is not necessary if the engine is warm.
- ⑦ Stop pushing the key when the engine has started.  
The key returns to the original position automatically.

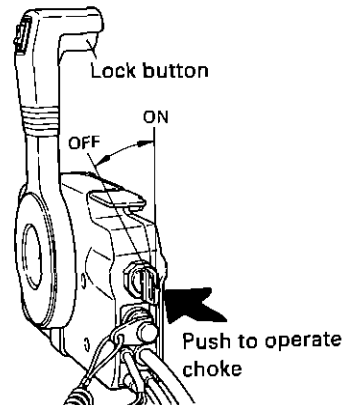

**Note:**

The neutral warm-up lever can not raise when the control lever shift in Forward or Reverse.

**Note:**

Types EF and EP

- Continuous operation of the starter motor shortens battery and starter motor life.  
Operate the starter motor for a maximum of 3 seconds. If the engine does not start, wait 5 seconds before engaging the starter motor again.
- Do not engage the starter motor after the engine has started.

**If the recoil starter or starter motor fails to operate**

- Remove the motor cover upper and the recoil starter and then pull direct on the starter rope by hand.
- Use a 10 mm socket wrench as a handle on the rope.

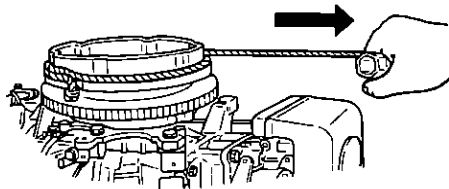

**▲CAUTION**

Be careful that your clothes or other items do not get caught in the rope or other engine parts.

To prevent getting things caught in the engine, do not re-attach the recoil starter after the engine has been started using the starter rope, but be sure to put the motor cover upper back on.

Immediately contact an authorized service shop when reaching shore.

## 5-2 Warming up the engine

Warm the engine at low engine speeds for about three minutes. This allows the lubricating oil to circulate to all parts of the engine. Operating the engine without warming it up shortens the engine's life.

Be sure to check that cooling water is coming out of the water check port when warming up the engine.

### Note:

If the engine is operated continuously without water discharging from the check port or idle hole, the engine may heat over.

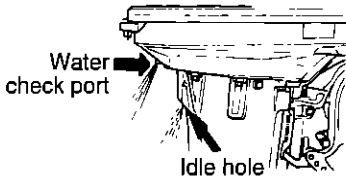

**25C<sub>3</sub>/30A<sub>4</sub>**

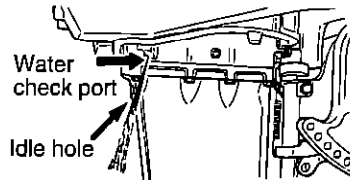

**40C**

- Engine speeds  
Idling speed after warming up.

Model	Clutch in	Clutch off
25C <sub>3</sub> / 30A <sub>4</sub>	900 rpm	1,050 rpm
40C	850 rpm	950 rpm

### PROPELLER SELECTION

Propeller must be selected so that the engine rpm when cruising with a wide-open throttle is within the recommended range.

Model	Wide-open throttle rpm range
25C <sub>3</sub>	5,000–6,000 rpm
30A <sub>4</sub>	5,150–5,850 rpm
40C	5,200–5,800 rpm

Genuine propellers are listed on PROPELLER TABLE of this manual.

### 5-3. Forward and reverse

## ▲ CAUTION

It may be dangerous to attempt shifting at high engine speed.  
Be sure to slow down to trolling or idling speed before shifting.

Note:

Do not increase Engine speed than necessary when reverse running.

NOTE: Confirm that the reverse lock lever is at "LOCK" position before running your motor.

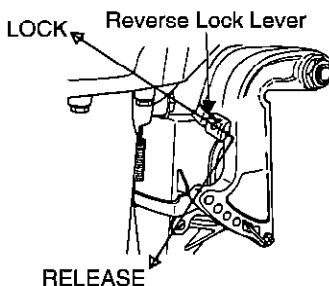

25C<sub>3</sub> / 30A<sub>4</sub> / 40C and EF type

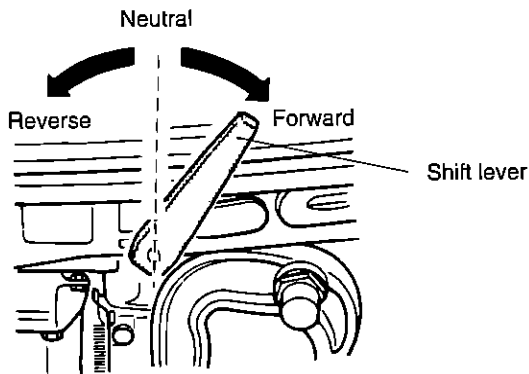

#### (1) Forward

Turn the throttle grip to reduce engine speed. When the engine reaches trolling speed, quickly pull the shift lever to the Forward position.

#### (2) Reverse

As when shifting to Forward, reduce the engine speed, when the engine reaches trolling speed, quickly push the shift lever to the Reverse position.

## EP type

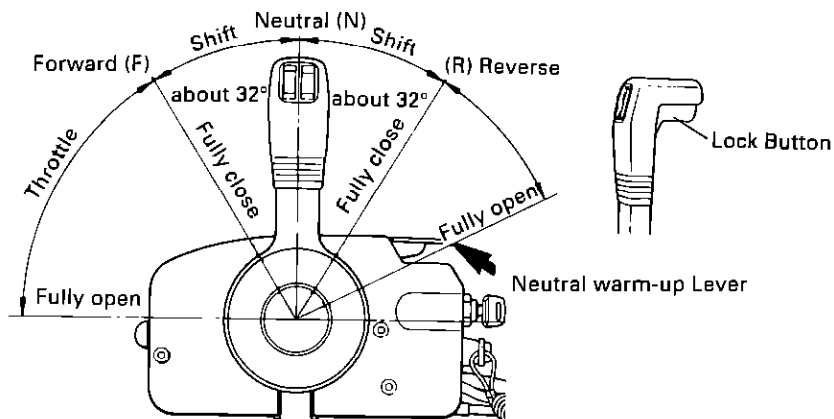

### (1) Forward

Quickly push the control lever to the Forward (F) position at 32°, where the gear is connected, while lifting up on the lock button located at the bottom of the control lever grip. Further shifting will open the throttle.

### (2) Reverse

Quick pull the control lever to the Reverse (R) position at 32°, where the gear is connected, while lifting up on the lock button located at the bottom of the control lever grip. Further shifting will open the throttle.

#### Note:

The Control Lever is inoperative unless the Neutral Warm-up Lever is in the fully closed position.

#### Note:

Reduce the engine speed when the Control Lever is in Neutral and do not increase the engine speed unnecessarily.

## 5-4. Stopping

### 25C<sub>3</sub> / 30A<sub>4</sub> /40C and EF type

- ① Turn the throttle grip to the low speed position.
- ② Put the shift lever in the Neutral position.  
Run the engine for 2~3 minutes at idling speed if it has been running at full speed.
- ③ Push the stop switch to stop the engine.

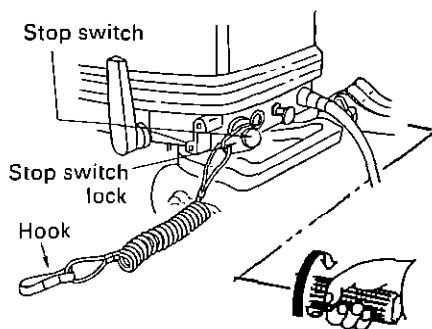

### EP type

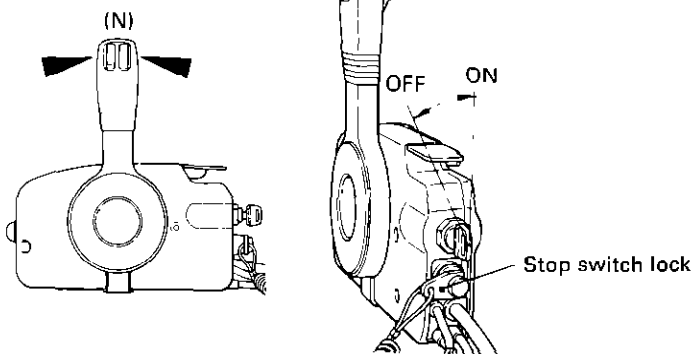

- ① Put the shift lever in the Neutral position and run the engine for 2~3 minutes at idling speed.
- ② Turn the main switch key to the OFF position or pull out the stop switch lock.

#### Note:

- After stopping the engine, close the air vent screw on the tank cap.
- Disconnect the fuel connector of the engine side.
- Disconnect the battery cord of the EF or EP type engine, if the engine will not be used for more than 3 days.



## 5-5. Trim angle

The trim angle of the outboard motor can be adjusted to suit the stern angle of the boat and the loading conditions. Choose an appropriate trim angle for the motor so that the anti-ventilation plate is parallel to water surface during operation.

- **Proper trim angle**

The position of the thrust rod is correct if the boat is horizontal during operation. (Fig. 1)

- **Improper trim angle**

Set the thrust rod lower the bow of the boat rises due to heavy pitching or unstable straight running. (Fig. 2)

- **Improper trim angle**

Set the thrust rod higher the bow of the boat goes under a wave. (Fig. 3)

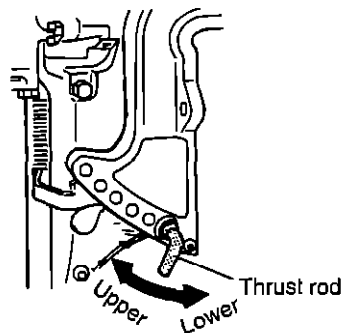
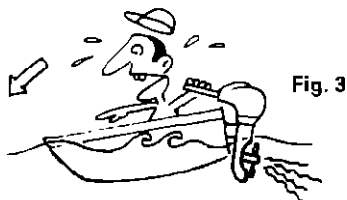
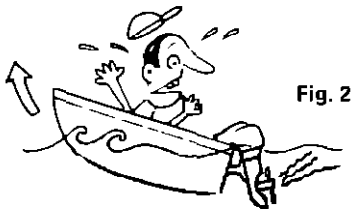
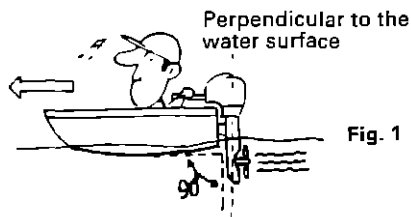

## 5-6. Tilt up, tilt down

### ⚠ WARNING

When tilting up or down, be careful not to place your hand between the swivel bracket and the stern bracket.  
Be sure to tilt the outboard down slowly.

Note:  
Stop the engine before tilting up.

#### (1) Tilt up

Push the reverse lock lever down until it stops. (This is the tilt up position). Now, tilt the engine all the way up until it is locked in place.

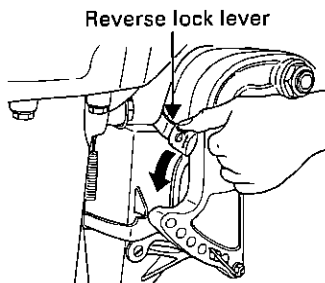

#### (2) Tilt down

Pull the reverse lock lever upward until it stops. (This is the tilt down position.) Now, lift up the engine slightly, and then allow gravity to lower it for you.

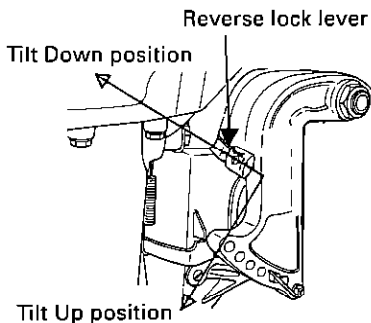

## 5-7. Shallow water operation

### **▲ WARNING**

When shallow water operation, be careful not to place your hand between the swivel bracket and the stern bracket.  
Be sure to tilt the outboard down slowly.

**Note:**

Slow down to trolling speed, and shift to the Neutral before shallow water operating.

(1) Tilt up

Put the reverse lock lever in the tilt up position, and tilt up the engine to put the engine in the shallow water running position.

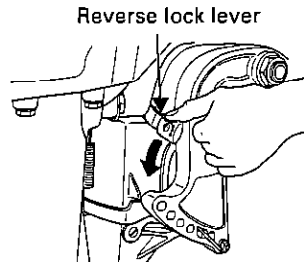

(2) Tilt down

Put the reverse lock lever in the tilt down position, slightly lift up the engine, and then put it down.

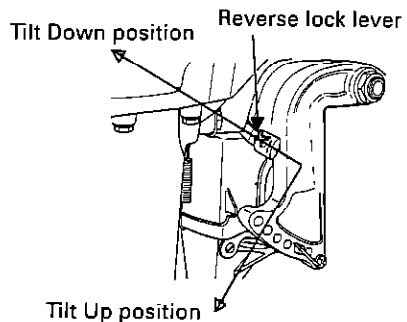

## **▲ CAUTION**

- Make sure that the water strainer is submerged at all times and that water is continuously running out of the cooling water check port.
- Be sure to run the engine slowly when using the shallow water drive. Running at higher speeds will result in lack of control and may damage the gear case and propeller.
- Make sure that the motor does not strike the bottom, especially when running in REVERSE. If the motor does strike the bottom while in reverse, the impact is transmitted to the transom, which could damage both the motor and the boat.

## 6. REMOVING AND CARRYING THE MOTOR

### 6-1. Removing the motor

- ① Stop the engine.
- ② Disconnect the fuel pipe connector, the remote control cables and the battery cords from the motor.
- ③ Remove the motor from the hull and completely drain the water from the gear case.

### 6-2. Carrying the motor

Be sure to keep the engine vertical posture whenever you carry the motor.

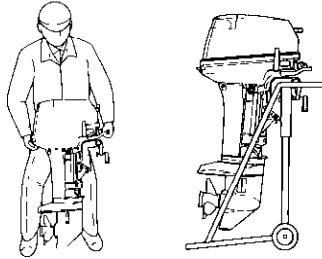

Note:

If you carry the motor horizontal posture, keep the power head higher than the propeller.

### 6-3. Storing the motor

Keep the motor vertical posture when you store it.

Note:

If you store the motor horizontal posture, lay the motor down on the ground with the handles facing upward.

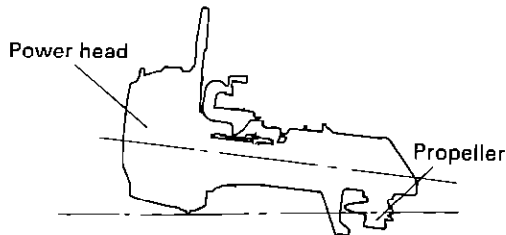

## 7. TRAILERING

### ▲ CAUTION

When trailering the engine installing on a boat, the motor should be in a running position fully tilting down. Trailering at tilted up condition of the motor may cause of damage to the motor, boat, etc. by unexpected tilt lock release getting a shock when trailering.

If trailering the motor at tilt down position is unavailable, fix the motor securely using a device (like a transom saver bar) at the tilting up position.

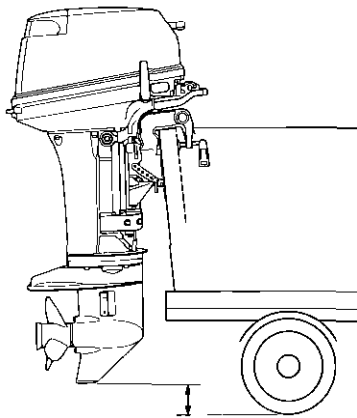

## 8. ADJUSTMENT

### ● Steering force

The steering force can be adjusted in accordance with your preference by turning the steering adjusting bolt.

For heavier steering ... Turn clockwise

For lighter steering .... Turn counterclockwise

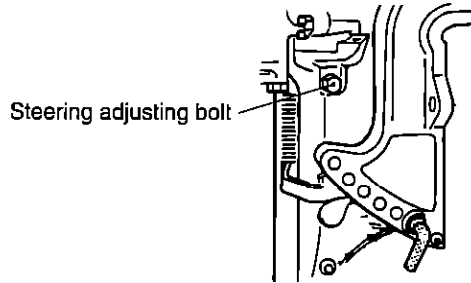

#### Note:

The steering adjust bolt is used to adjust the sliding load of the steering, but not to fix the steering. If excess tightening given to the bolt may lead a cause of damage to the swivel bracket.

### ● Trim tab adjustment

If straight-line cruising cannot be achieved, adjust the trim tab located under the anti-ventilation plate.

- If the boat veers toward the right, set the trim tab in the direction of A.
- If the boat veers toward the left, set the trim tab in the direction of B.

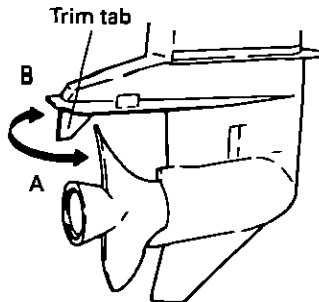

## 9. INSPECTION AND MAINTENANCE

### Care of your outboard motor

To keep your motor in the best operating condition, it is very important that you perform daily, and periodic, maintenance as suggested in the maintenance schedules that follow.

### **⚠ CAUTION**

- Your personal safety and that of your passengers depends on how well you maintain your outboard motor. Carefully observe all of the inspection and maintenance procedures described in this section.
- The maintenance intervals shown in the checklist apply to an outboard motor in normal use. If you use your outboard motor under severe conditions such as frequent full-throttle operation or frequent operation in brackish water, maintenance should be performed at shorter intervals. If in doubt, consult your dealer for advice.
- We strongly recommend that you use only genuine replacement parts on your outboard motor. Damage to your outboard arising from the use of other than genuine parts is not covered under the warranty.

### **EPA Emissions Regulations**

EPA (United States Environmental Protection Agency) has emission regulations and is controlling air pollution from new outboard motors. All new motors manufactured by us are certified to EPA as conforming to the requirements of the regulations. This certification is depend upon factory standards. Therefore, factory specifications must be followed when servicing emission related controls, or making adjustments. **Maintenance, replacement, or repair of the emission control devices and systems may be performed by any marine SI (Spark Ignition) engine repair establishment or individual.**



## 9-1. Daily Inspection

Perform the following checks before and after use.

Item	Points to Check	Action
Fuel System	<ul style="list-style-type: none"> <li>Check the amount of fuel in the tank.</li> <li>Check for debris or water in the fuel filters.</li> <li>Check the rubber hoses for fuel leakage.</li> </ul>	Replenish Clean Replace
Electrical Equipment	<ul style="list-style-type: none"> <li>Check that the main switch functions normally.</li> <li>Check that the battery electrolyte level and specific gravity are normal.</li> <li>Check for loose connections on the battery terminal</li> <li>Check that the stop switch functions normally and make sure the lock plate is there.</li> <li>Check cords for loose connections and damage.</li> <li>Check the spark plugs for dirt, wear and carbon build-up.</li> </ul>	Replace Replenish or recharge  Retighten  Remedy or replace  Correct or replace Clean or replace
Choke and Throttle System	<ul style="list-style-type: none"> <li>Check that the choke solenoid and valve for the carburetor function normally.</li> <li>Check if the carburetor and magneto work normally when turning the throttle grip, and check the links for looseness.</li> </ul>	Replace  Correct
Recoil Starter	<ul style="list-style-type: none"> <li>Check the ropes for wear and damage.</li> <li>Check the latchet for engagement.</li> </ul>	Replace  Correct or replace
Clutch and Propeller System	<ul style="list-style-type: none"> <li>Check that the clutch engages correctly when operating the shift lever and remote control.</li> <li>Visually check the propeller for bent or damaged blades</li> <li>Check that the propeller nut is tightened and the split pin is there</li> </ul>	Adjust  Replace
Installation of Motor	<ul style="list-style-type: none"> <li>Check all the bolts attaching the motor to the boat.</li> <li>Check the thrust rod installation.</li> </ul>	Tighten
Cooling Water	<ul style="list-style-type: none"> <li>Check that cooling water is discharged from the cooling water check port after the engine has started</li> </ul>	
Tools and Spares	<ul style="list-style-type: none"> <li>Check that there are tools and spare parts for replacing spark plugs, the propeller, etc.</li> <li>Check that you have the spare rope.</li> </ul>	
Steering Devices	<ul style="list-style-type: none"> <li>Check the operation of the steering handle and remote control</li> </ul>	
Other parts	<ul style="list-style-type: none"> <li>Check if the anode and trim tab are securely installed.</li> <li>Check the anode and trim tab for corrosion and deformation</li> </ul>	Repair if necessary Replace

### A. Washing

After operating the motor in sea water or polluted water, or if it will be stored for a long period, wash all enclosures and the water cooling system with fresh water.

#### **▲ WARNING**

Before flushing, remove the propeller.

#### **▲ WARNING**

Never start or operate the engine indoors or in any space which is not well ventilated. Exhaust gas contains carbon monoxide, a colorless and odorless gas which can be fatal if inhaled for any length of time.

- Remove the water plug from the motor, and screw in the flushing plug (hose adapter).  
Connect a hose to the flushing plug to flush out the inside of the motor with water. (Be sure to seal the water strainer and sub water strainer, located in the gear case, with tape.)  
Remark: Sub water strainer is only for 25C<sub>3</sub> / 30A<sub>4</sub>.
- With the shift lever in Neutral (N), run the engine at a low speed while flusing the cooling system to ensure all sea water and mud are removed.

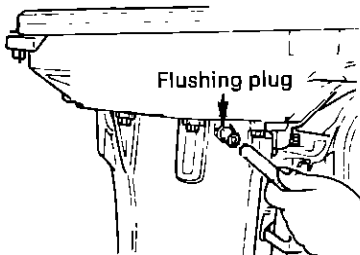

25C<sub>3</sub>/30A<sub>4</sub>

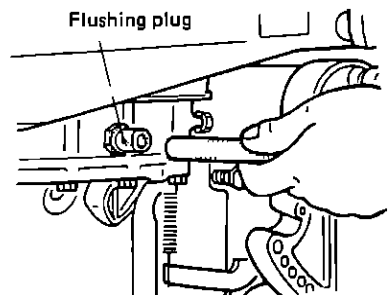

40C

## B. Replacing the propeller

A worn-out or bent propeller will lower the motor's performance, and cause engine trouble.

### ⚠ CAUTION

Before removing the propeller, remove the spark plug caps from the spark plugs to protect the propeller from damage.

- ① Take out the split pin, and remove the propeller nut and washer. (& stopper for 40C)
- ② Pull the propeller toward you and remove it.
- ③ Apply genuine grease to the propeller shaft before putting a new propeller on.

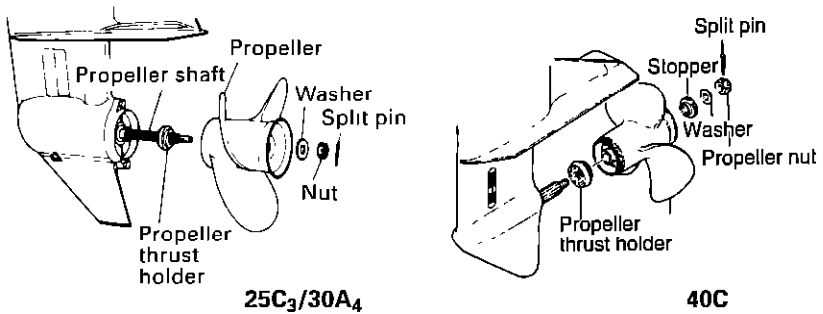

## C. Replacing the spark plugs

If the electrode is fouled, has carbon deposits or is worn, clean or replace it as necessary.

- ① Remove the motor cover upper.
- ② Remove the spark plug by turning counter-clockwise, using a 21 mm socket wrench and handle.

Use spark plugs (NGK B7HS-10 or BR7HS-10) or recommended ones (CHAMPION L 82 C or RL 82 C with 1.0 mm gap).

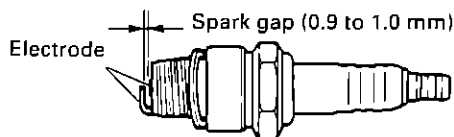

#### D. Replacing the anodes

A sacrificial anode protects the outboards from the electrolytic corrosion (metallic corrosion developed by feeble electricity). Three anodes are fitted at the gear case, the mount bracket and in the cylinder, and when the anodes has been eroded more than 2/3, replace it immediately.

Remark: The trim tab is concurrently anode.

**Note:**

- *Never grease or paint the anode.*
- *At each inspection, retighten the anode fixing bolt, as it is likely to be subjected to electrolytic corrosion.*

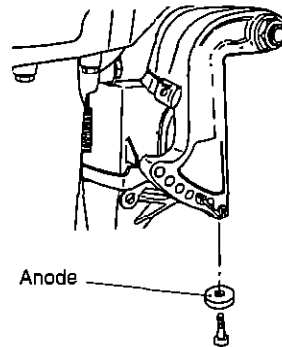
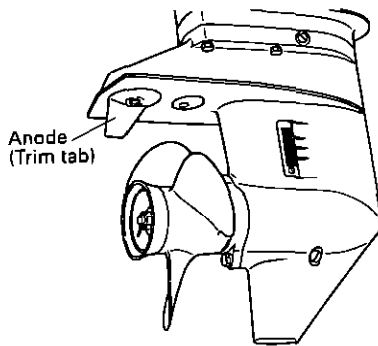

## 9-2. Periodic Inspection

It is important to inspect and maintain your outboard motor regularly. At each interval on the chart below, be sure to perform the indicated servicing. Maintenance intervals should be determined according to the number of hours or number of months, whichever comes first.

Item		Servicing Interval			Action	Remarks
		10 hours or 1 month	50 hours or 3 months	Every 100 hours or 6 months		
Fuel System	*Carburetor	○		○	Strip, clean, and adjust Adjust idling	
	Fuel filter	○	○	○	Check and clean	
	Piping	○	○	○	Check and Replace.	
	Fuel tank		○	○	Clean.	
Ignition	Spark plugs		○	○	Check gaps Remove carbon deposits or Replace.	
	*Ignition timing	○		○	Adjust timing.	
Starting System	*Starter motor			○	Check for salt deposits and the battery cable condition	
	Battery	○	○	○	Check installation, fluid quantity, gravity.	
	Starter rope	○	○	○	Check for wear or damage.	
Lower Unit	Propeller	○	○	○	Check for bent blades, damage, wear.	
	Gear oil	○	○	○	Change or replenish-oil and check for water leaks.	
	*Water pump		○	○	Check for wear or damage.	Replace impeller every 12 months
Bolts and Nuts		○	○	○	Retighten.	
Sliding and Rotating Parts Grease Nipples			○	○	Apply and pump in grease.	
Outer Equipment		○	○	○	Check for corrosion.	
Anode			○	○	Check for corrosion and deformation.	Replace.

\* Have this handled by the dealer.

### Note:

Your outboard motor should receive careful, and complete, inspection at 300 hours. This is the best time for major maintenance procedures to be carried out.

### A. Changing gear oil

- 1) Remove the oil plugs (upper and lower), and drain the gear oil completely.

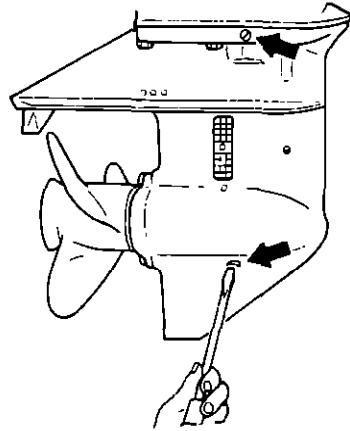

- 2) Insert the oil tube nozzle into the lower oil plug hole, and fill with gear oil by squeezing the oil tube until oil flows out of the upper plug hole.

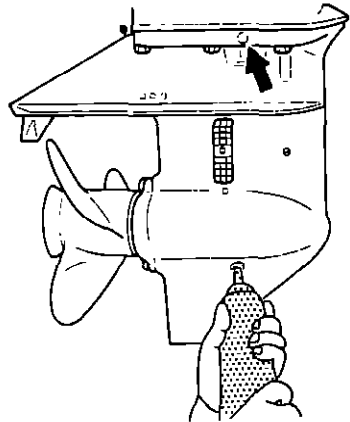

- 3) Install the upper oil plug, and then remove oil tube nozzle and install the lower oil plug.

**Note:**

Use genuine gear oil or the recommended one (API GL-5: SAE #80 to #90).

Required volume: approx. 280 mL (0.07 U.S. gal.) — 25C<sub>3</sub> / 30A<sub>4</sub>  
approx. 420 mL (0.11 U.S. gal.) — 40C

## B. Cleaning the fuel filters and the fuel tank

Fuel filters are provided inside the fuel tank and engine.

### ① Fuel tank filter

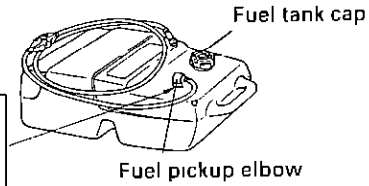
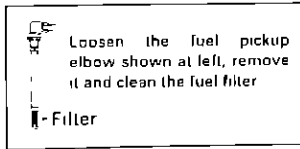

### ② Engine filter

Remove the cap, then clean the fuel filter in the engine.

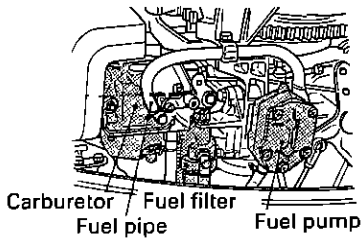

25C<sub>3</sub>/30A<sub>4</sub>

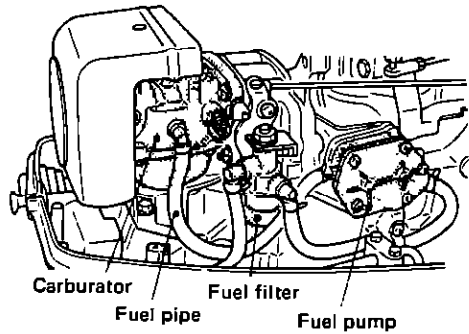

40C

### ③ Fuel tank

Water or dirt in the fuel tank may cause engine trouble.

Clean the tank at specified times or after the motor has been store for a long period (over three months).

### 9-3. Off-season storage

When you are ready to put your outboard motor in storage, it is a good opportunity to have it serviced and overhauled by your dealer.

## **▲ CAUTION**

Before servicing the motor for storage:

- Remove the positive (+) battery cord.
- Remove the spark plug caps from the spark plugs.
- Do not run the motor out of the water.

### A. Engine

- ① Wash the engine exterior and flush the cooling water system thoroughly with fresh water. Drain the water completely.  
Wipe off any surface water with an oily rag.
- ② Use a dry cloth to completely wipe off water and salt from the electrical components.
- ③ Drain all fuel from the fuel pipes, fuel pump, and carburetor, and clean these parts.  
Keep in mind that if gasoline is kept in the carburetor for a long time, gum and varnish will be generated, causing the float valve to stick.
- ④ Remove the spark plugs and feed genuine engine oil or storage fogging oil in through the spark plug holes.  
The oil will be fed into the crank case from the air silencer attached to the carburetors. Turn the engine over several times while feeding the oil into it and make sure it is evenly distributed.
- ⑤ Change the gear oil in the gear case.
- ⑥ Apply grease to the propeller shaft.
- ⑦ Apply grease to all sliding parts, joints, nuts, and bolts.
- ⑧ Stand the engine up vertically in a dry place.

### B. Battery

- ① Disconnect the battery cables.
- ② Wipe off any chemical deposits, dirt, or grease.
- ③ Apply grease or vaseline to the battery terminals.
- ④ Charge the battery completely before storing it for the winter.
- ⑤ Recharge the battery once a month to prevent it from discharging and the electrolyte from deteriorating.
- ⑥ Store the battery in a dry place.



### C. Electric Starter Motor

Coat the pinion gears and the shaft of the electric starter motor with grease.

#### 9-4. Pre-season check

- ① Check the electrolyte level, and measure the voltage and specific gravity of the battery.

Specific Gravity at 20°C	Terminal Voltage (V)	Charge Condition
1.120	10.5	Fully discharged
1.160	11.1	1/4 charged
1.210	11.7	1/2 charged
1.250	12.0	3/4 charged
1.280	13.2	Fully charged

- ② Check that the battery is secure and the battery cables are properly installed.
- ③ Check that the shift and throttle function properly.  
(Be sure to turn the propeller shaft when checking the shift function or else the shift linkage may be damaged.)

**Note:**

The following steps must be taken when first using the engine after winter storage.

- 1 Fill up the fuel tank completely with 25 liters (6.6 U.S. gals.)  
Mixing ratio: Gasoline 25:1 Engine oil  
Use unleaded gasoline and genuine Outboard Motor Oil. If this oil is not available, use NMMA TC-W 3 certified outboard motor oil.
2. Warm up the engine for 3 minutes in the "NEUTRAL" position.
3. Run the engine for 5 minutes at the slowest speed.
4. Run the engine for 10 minutes at half speed.  
: In Steps 2 and 3 above, the oil used for storage inside the engine will be finished out to assure optimum performance.

### **9-5. Motor submerged in water**

After taking your motor out of the water, immediately take it to your dealer.

The following are the emergency measures to be taken for a submerged outboard, if you can not take it to your dealer right away.

- 1) Wash the motor with fresh water to remove salt or dirt.
- 2) Remove the spark plugs, and completely drain the water from the engine by pulling the recoil starter several times.
- 3) Inject a sufficient amount of genuine engine oil through the spark plug hole and into the crank case from the carburetor side. Pull the recoil starter several times to circulate the oil throughout the motor.

### **9-6. Cold weather precautions**

If you moor your boat in cold weather at temperatures below 0°C (32°F), there is the danger of water freezing in the cooling water pump, which may damage the pump, impeller, etc. To avoid this problem, submerge the lower half of the motor in water, or tilt the motor up above water level and pull the recoil starter several times to drain the water completely.

### **9-7. Checking after striking underwater object**

Striking the sea bottom or an underwater object may severely damage the outboard. Immediately bring the outboard to the dealer and ask for the following checks.

- (1) Looseness or damage of power unit installation bolts, gear case and extension case bolts, propeller shaft housing bolts, upper and lower mount rubber bolts, and/or mount bracket bolts.

Ask the dealer to tighten any loose bolts any nuts, and to replace damaged parts.

- (2) Deformation and damage of mount rubber, the tilt stopper, thrust rod, gears and clutch, and/or propeller.

Ask the dealer to replace damaged or defective parts.

## 10. TROUBLESHOOTING

If you encounter a problem, consult the check list below to determine the cause and to take the proper measure.

Your dealer will always be happy to provide any assistance and information.

	Engine failing to start	Engine starting but stopping soon	Poor idling	Poor acceleration	Engine speed abnormally high	Engine speed abnormally low	High engine speeds not possible	Overheating of engine	Possible cause
FUEL SYSTEM	•	•							Empty fuel tank
	•	•	•	•		•	•	•	Incorrect connection of fuel system
	•	•	•	•		•	•	•	Air entering fuel line
	•	•	•	•		•	•	•	Deformed or damaged fuel pipe
	•	•	•	•		•	•	•	Closed air vent on fuel tank
	•	•	•	•		•	•	•	Clogged fuel filter, fuel pump, or carburetor
			•	•		•	•	•	Use of improper engine oil
	•		•	•			•	•	Use of improper gasoline
	•	•	•	•			•		Excessive oil in mixture
								•	Shortage of oil in mixture
	•			•					Excessive supply of fuel
	•	•	•	•		•	•	•	Poor carburetor adjustment
	•	•	•	•			•	•	Recirculation pipe broken
		•	•	•	•		•	•	•
	•	•	•	•		•	•		Dirt, soot, etc. on spark plugs

	Engine failing to start	Engine starting but stopping soon	Poor idling	Poor acceleration	Engine speed abnormally high	Engine speed abnormally low	High engine speeds not possible	Overheating of engine	Possible cause	
ELECTRIC SYSTEMS	•	•	•	•		•	▪		No spark or weak spark	
	•								Short circuit of engine stop switch	
	•		•	•		•	▪		Incorrect adjustment of ignition timing	
	•								Loose battery terminal connection, corrosion	EP and EF types
	•								Discharged battery	
	▪								Main switch trouble	
	•								Lock plate not fitted to stop switch	
	•								Disconnection of wire or loose ground connection	
	•								Insufficient battery capacity, loose terminal connection, corrosion	EP and EF types
	OTHERS	•		•	•		•	▪		Incorrect adjustment of throttle link
							•	•	Insufficient cooling water flow, clogged or defective pump	
			•				•	•	Faulty thermostat	
				•	•		•	•	Cavitation or ventilation	
				•	•	•	•	•	Incorrect propeller selection	
			•	•	•	•	•	•	Damaged and bent propeller	
				•	•		•	•	Improper thrust rod position	
				•	•	•	•	•	Unbalanced load on boat	
				•	•	•	•	•	Transom too high or too low	

## 11. TOOL KIT AND SPARE PARTS

The following a list of the tools and spare parts provided with the motor.

Items		Quantity	Dimensions	Remarks		
Service tools	Tool bag	1	10 x 13 mm 21 mm			
	Pliers	1				
	Socket wrench	1				
	Socket wrench	1				
	Socket wrench handle	1				
	Straight edge screw-driver	1				
Spare parts	Starter rope	1	1000 mm NGKB7HS-10 or CHAMPION L82C (Gap: 1.0 mm)			
	Spark plug	1				
	Split pin	1				
Parts Packaged with Engine*	Fuel tank	1				
	Primer bulb	1 set				
	Remote control box	1 set			EP only	
	Remote control attachment	1 set			EP only	
	Drag link	1 set			EP only	
	Bracket fixing bolt	2			8 mmx85 mm 8 mm	EP only
	Bracket fixing nut	2				EP only
Washer	4	EP only				
	Flushing plug	1				

\* Not provided with the motor in some markets.

## 12. OPTIONAL ACCESSORIES

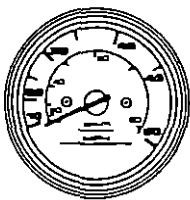

Speedometer  
(50MPH)

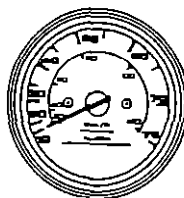

Speedometer  
(75MPH)

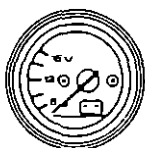

Voltmeter

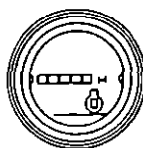

Hour Meter  
(engine operation  
hour counter)

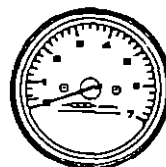

Tachometer

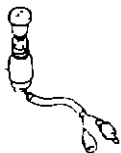

Meter lamp switch

Clutch lever  
reverse lock kit

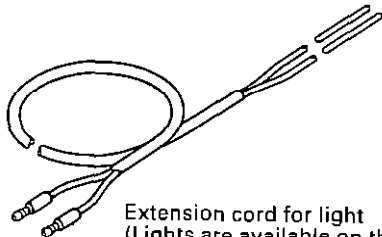
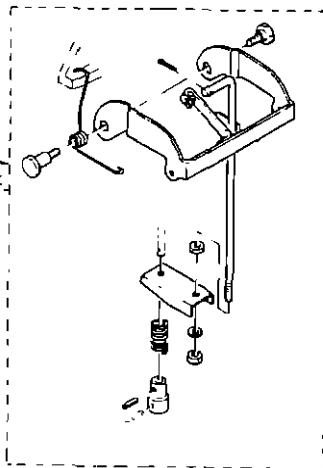

Extension cord for light  
(Lights are available on the market.)

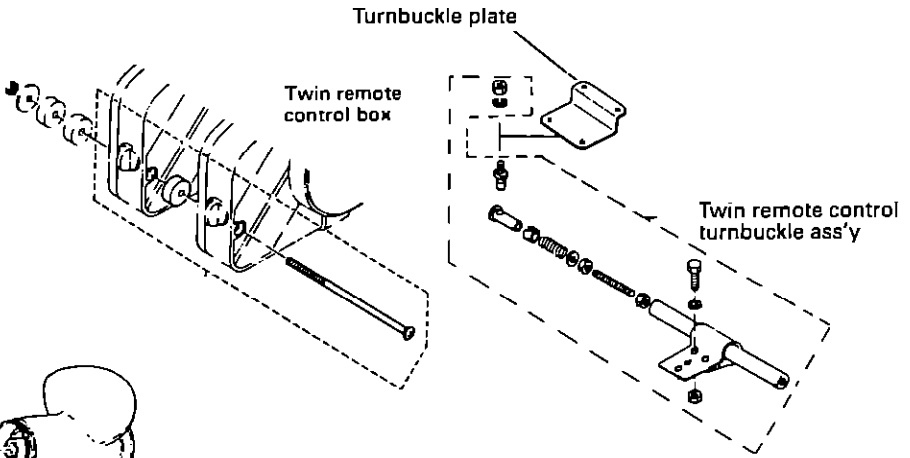
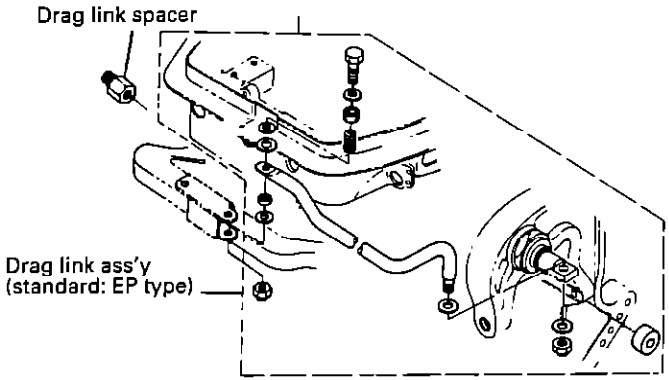

Propeller

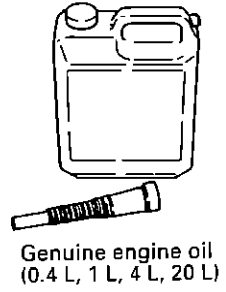
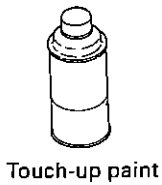

### 13. PROPELLER TABLE

Use a genuine propeller.

A propeller must be selected so that the engine rpm measured at wide open throttle while cruising is within the recommended range: 25C<sub>3</sub> = 5000 to 6000 rpm; 30A<sub>4</sub> = 5150 to 5850 rpm. 40C = 5200 to 5800 rpm.

#### 25C<sub>3</sub> / 30A<sub>4</sub>

	Light boats			Heavy boats			
Size as Indicated on propeller	14	13	11	10	9	8	
Propeller Size Diameter × pitch	(mm)	252 × 360	252 × 332	250 × 288	250 × 260	249 × 236	260 × 210
	(inch)	9.9 × 14.2	9.9 × 13.1	9.8 × 11.3	9.8 × 10.2	9.8 × 9.3	10.2 × 8.3
STD or Option	○	S	L	UL	○	○	

○: Option

S (short), L (long), UL (extra long): STD

#### 40C

	Light boats				Heavy boats				
Size as Indicated on propeller	14	13	12	11	10	9	8.5	7*	
Propeller Size Diameter × pitch	(mm)	260 × 352	262 × 322	268 × 296	268 × 287	275 × 252	276 × 226	285 × 220	290 × 180
	(inch)	10.2 × 13.9	10.3 × 12.7	10.6 × 11.7	10.6 × 11.3	10.8 × 9.9	10.9 × 8.9	11.2 × 8.7	11.4 × 7.1
	○	○	○	S, L, UL	○	○	○	○	

○: Option

S (short), L (long), UL (extra long): STD

Note: Propellers are 3-blades type except \*marked one.

\*marked propeller has 4-blades.



# 14. WIRING DIAGRAM (25C<sub>3</sub> / 30A<sub>4</sub> / 40C)

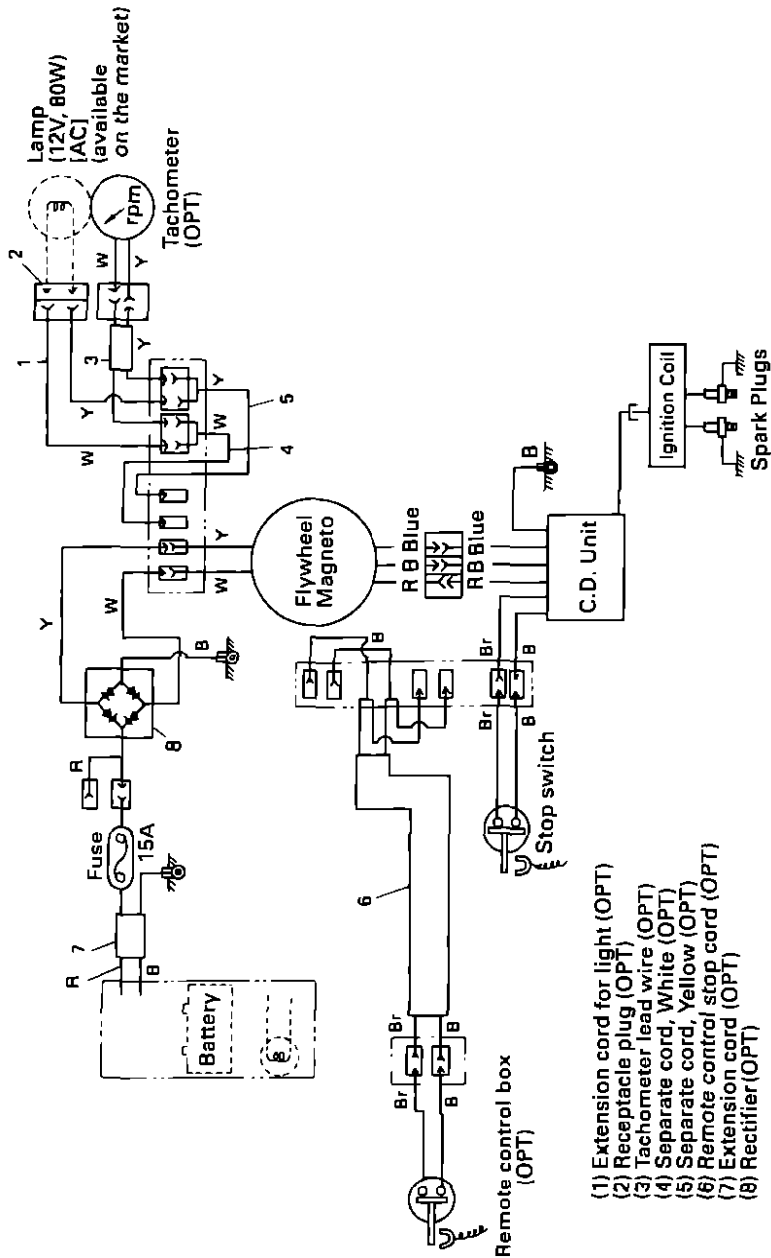

- (1) Extension cord for light (OPT)
- (2) Receptacle plug (OPT)
- (3) Tachometer lead wire (OPT)
- (4) Separate cord, White (OPT)
- (5) Separate cord, Yellow (OPT)
- (6) Remote control stop cord (OPT)
- (7) Extension cord (OPT)
- (8) Rectifier (OPT)

OPT: Option

# WIRING DIAGRAM (EF type)

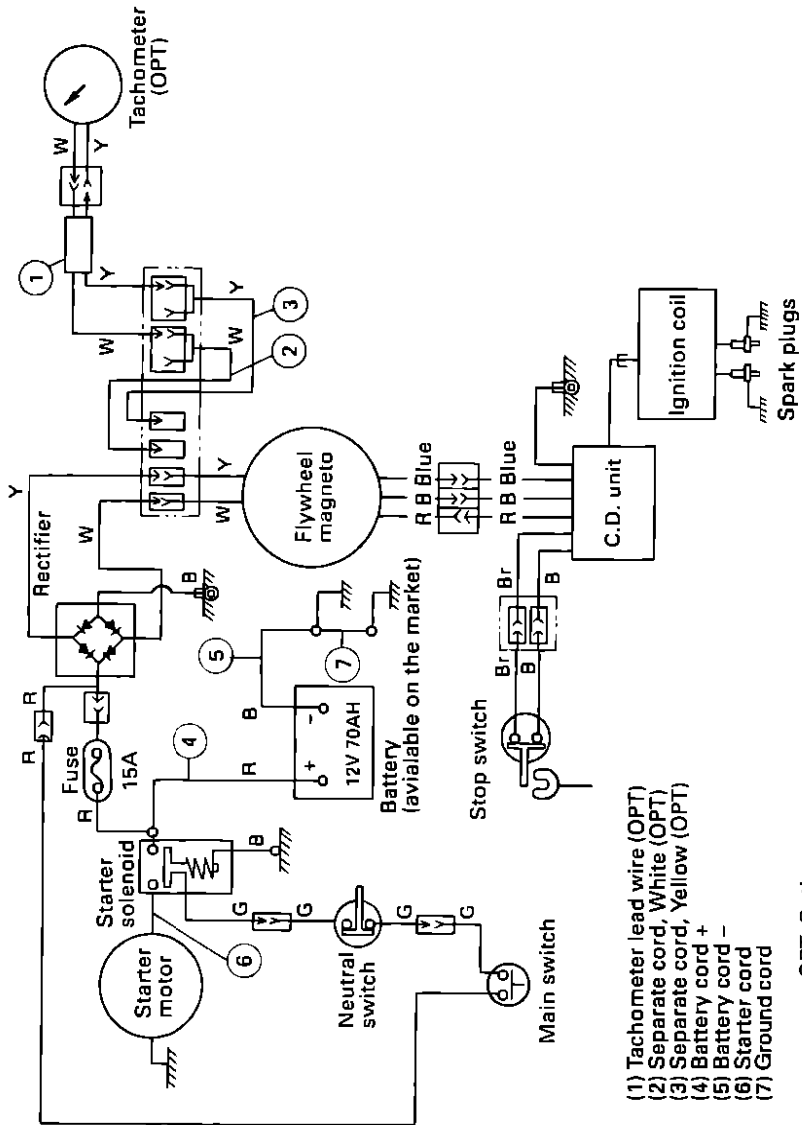

# WIRING DIAGRAM (EP type)

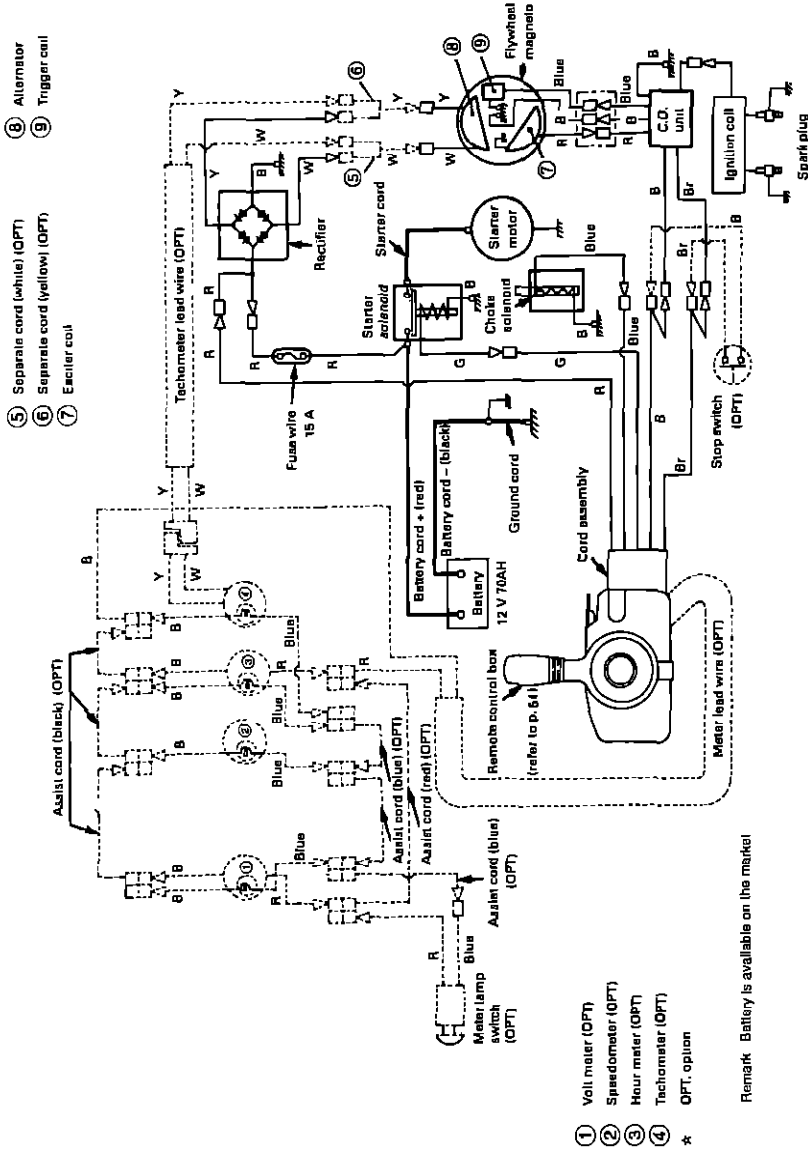

# WIRING DIAGRAM (Single Remote Control Box)

